

The Casks from the Wreck of the *William Salthouse*

MARK STANIFORTH

Casks were the most common containers for the shipment of bulk commodities during the nineteenth century. Cooperage, the trade of making casks, has declined during the twentieth century to the point where two of the three branches of the trade have ceased to exist. The remains of the cask cargo found on the wrecksite of the William Salthouse provided an opportunity to study cooperage technology, the marking of casks, cask contents and stowage methods in a nineteenth-century sailing vessel. This paper discusses some of the results obtained during a short test excavation of the wrecksite in 1983. By comparing the archaeological evidence with the historical document it has been possible to demonstrate the use of sub-standard components and poor quality workmanship. The increasing need for legislation to regulate standards and to ensure quality control is discussed. The author was the State Maritime Archaeologist with the Victoria Archaeological Survey, and is currently a curator at the Australian National Maritime Museum.

INTRODUCTION

When faced with today's multitude of consumer goods packaged in a variety of wooden crates, cardboard boxes and plastic wrapping, it is hard to appreciate that this is a purely twentieth-century phenomenon. Until the latter part of the nineteenth century only a small proportion of consumer goods were individually packaged. Most goods were packed, shipped, and sold in bulk. Smaller transactions occurred only at the retail level, where the store owner transformed bulk quantities into individual units. The most common bulk container in use during the nineteenth century was the cask; now more commonly referred to as the barrel. 'Cask' was the generic term for a wooden-staved container, which could vary in size from the tiny firkin, or keg, of 9 gallons (41 litres) capacity, to the mighty tun of 252 gallons (1146 litres) capacity. The terms used to describe the different sizes of casks varied over time. However, some of the most commonly used terms are listed in Table 1.

Table 1: Types of cask.

Name	Equivalent in barrels	Capacity in British gallons	Capacity in litres
Puncheon	2	72	327
Hogshead	1½	54	245
Tierce	1¼	42	191
Barrel	1	36	164
Half Barrel (Kilderkin)	½	18	82
Firkin (Keg)	¼	9	41

Cooperage is the trade of making casks and other wooden-staved containers. It is one of the oldest trades in existence: casks having been made for over 2500 years.¹ Cooperage has always been the preserve of the professional craftsman; no-one made casks as a hobby. The past century has seen a dramatic decline in cooperage and two branches of the cooper's trade have vanished entirely. Indeed, as we reach the close of the twentieth century, there are few coopers left alive who have experience in all three branches of the trade. These three branches were:

1. Wet cooperage.

This is the only branch of the trade which still exists and the one most people will be familiar with. Wet

cooperage is the process by which iron-hooped casks are constructed to hold liquids such as vinegar, spirits, wines and other alcoholic beverages.

2. White cooperage.

This was the process of making tubs and buckets with wooden staves. It had many features in common with wet cooperage, in that the open-ended containers were often constructed to hold liquids and thus had to be watertight.

3. Dry cooperage.

This was the branch of cooperage which produced the simplest, least robust type of casks. The dry-cooperage process produced two types of wooden-hooped cask: the so-called dry tight cask which was used to transport powdery or semi-liquid products such as flour or salted provisions and the dry slack cask which was used for the shipment of nails, fruit, biscuits and so on.

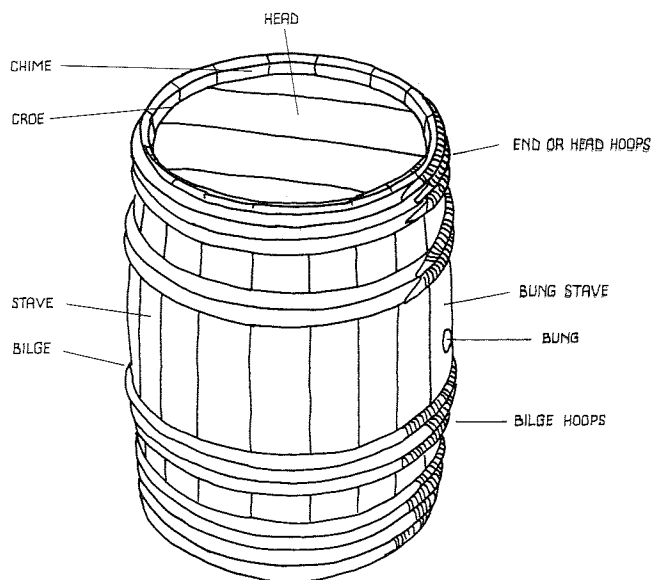

Fig. 1: Typical cask. (After Ross 1980b.)

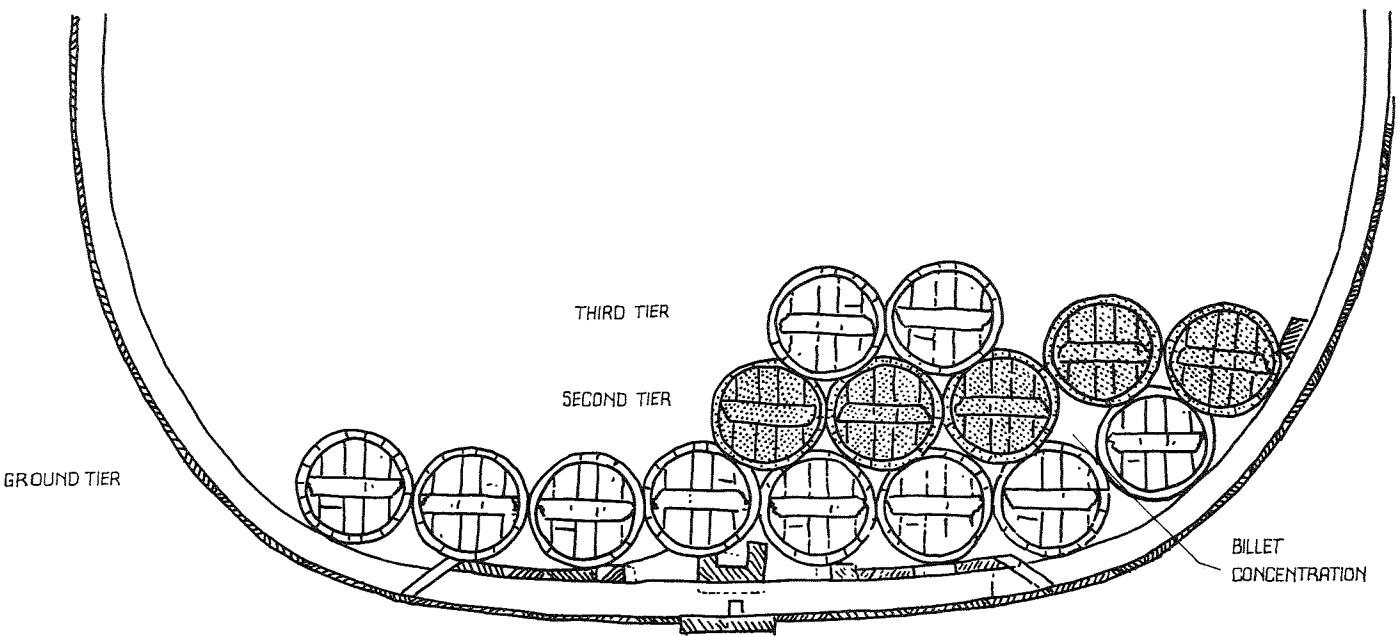

Fig. 2: Stowage of casks aboard ship. (After Ross 1980b.)

Casks, whether constructed by the wet or dry-cooperage process, consist of three major structural elements: staves, heads and hoops. A stave is a curved plank of wood made to fit tightly on two sides against other staves, to form the sides of a cask. A head is the circular end of a cask made up of one or more pieces of timber. Hoops are narrow strips of wood or iron placed around the circumference of a cask² (Fig. 1).

The technology of dry cooperage was basically similar to those of the other branches of cooperage. However, the materials and workmanship employed usually resulted in a poor quality wooden-hooped cask, made of cheaper lighter timber, which was only used for a single trip. Unlike wet-coopered casks, they were not usually washed out and reused. Consequently, dry-coopered casks were an early example of throw-away technology. They were not built to last and in the terrestrial environment very few examples remain today.

Casks were used to transport almost all types of commodities. Because of their shape and ease of handling, casks were particularly suitable for stowage aboard sailing ships (Fig. 2). Providing they were regulated in size and capacity according to their intended contents, they made it easier to weigh, store and carry out customs evaluations of bulk commodities.

Casks were stowed in vessels in several different ways: the most common of which was the bilge and cantline method of stowage. In bilge and cantline stowage the ground tier, or bottom layer, of casks was laid fore and aft on the ceiling, or inner, planking of the vessel and the second tier was placed such that the bilge, or widest part, of each cask lay in the cantline, or hollow, formed by four casks in the ground tier (Fig. 3). Texts on stowage recommended bilge and cantline as the most efficient and preferred method of stowage but also mentioned that other methods were used, for example bilge and bilge, a-burton (across the vessel) and vertical stowage.³

Undoubtedly the best archaeological examination of cooperage technology and staved containers, has been the work carried out by Parks Canada over the past decade, during the excavation of the sixteenth-century Basque whaling galleon *San Juan*, which sank at Red Bay,

Fig. 3: Bilge and cantline method of stowage. (After Ross 1980b.)

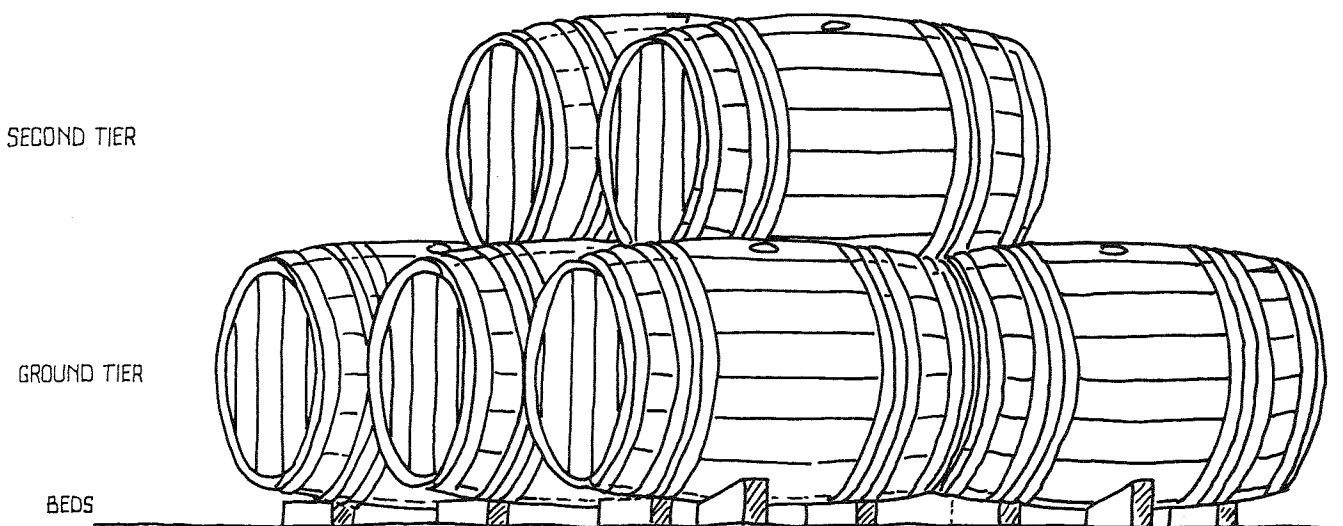

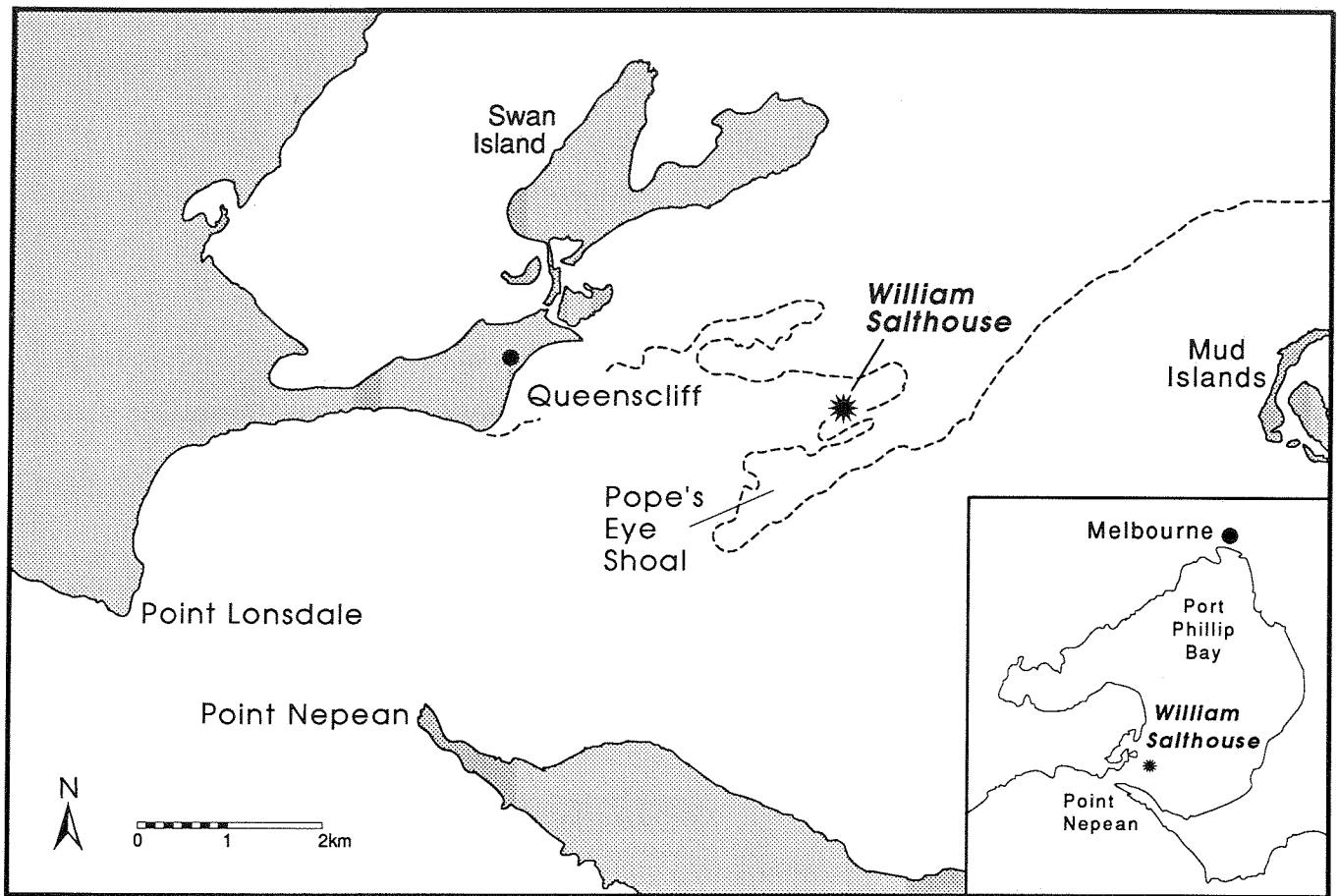

Fig. 4: Site location.

Labrador, Canada.⁴ Furthermore, Parks Canada has conducted examinations of the historical literature relating to British powder barrels⁵ and of the statutes relating to the package of bulk commodities in casks.⁶ Copies of the British North American statutes relating to the package of flour, pork, beef and fish were obtained from Parks Canada.

THE VESSEL

In late November 1841 the 250-ton brig *William Salthouse* hit a submerged rock off Point Nepean and despite the attempts of the crew to save her, sank on Pope's Eye Shoal near Queenscliff in Victoria (Fig. 4). The vessel was at the end of a four to five month voyage from Canada and sank almost within sight of her destination: the five-year-old settlement of Port Phillip at Melbourne. The British registered *William Salthouse* was the first trading vessel to make the voyage from Canada to any Australian port and thus Canadian–Australian trade had a somewhat inauspicious beginning.⁷

Among the items listed in the vessel's manifest were over 1000 casks of various capacities.⁸ These contained mainly flour and salted provisions but also included whisky, cider, vinegar and nails. Most of the casks were constructed by the dry-cooperage process: the majority being dry tight casks (flour and salted provisions).

THE EXCAVATION

In March and April 1983 the Maritime Archaeological Unit (MAU) of the Victoria Archaeological Survey conducted a test excavation on the wrecksite over a six-week period.⁹ The main aims of this project were concerned with questions of site-management, such as the determination of the extent of the site and an evaluation of the damage caused by sports divers. It was intended to be a basis for future evaluations of the deterioration of the site through environmental and human influences. During the test excavation, two shallow trenches were excavated one forward and one aft of the main mast. These trenches were only excavated until complete casks were encountered, when, due to the difficulty of raising and conserving complete casks, the excavation ceased and the trenches were refilled. No complete casks were raised and the majority of the material raised came from the unconsolidated upper layers of the wrecksite, where considerable disturbance by sports divers had occurred (Fig. 5).

The secondary aims of the excavation were concerned with the study of the technology and marking of the casks, and of the stowage methods demonstrated in this vessel. There were also wider implications, in terms of questions about the need for and possible utilization of the cask cargo in the settlement of Port Phillip. It is the results which relate to these secondary aims which are the subject of this paper.

THE CASKS

During the excavation thirty-six cask staves, forty-one complete or partial cask heads, and samples of hoops,

dunnage and stowage materials were raised. In addition, twenty cask staves were confiscated from scuba divers, who had raised them before the wrecksite was declared an historic shipwreck under the provisions of the Victoria Historic Shipwrecks Act 1981. These staves were returned to the Victoria Archaeological Survey by the Police. Unfortunately, they had simply been left to dry and had suffered to a greater or lesser degree from warpage or shrinkage.

Heads

Of the eight complete and thirty-three partial heads raised during the excavation, the majority (twenty-nine) were made of oak, while twelve were of pine or elm. Based on the data from the complete heads, the 'average' cask head was made of two or three pieces of timber held together by two dowels per joint. The heads were of four principal sizes:

1. Tierce: 520 mm diameter (20½ inches).
2. Barrel: 440 mm diameter (17 inches).
3. Half Barrel: 350 mm diameter (13½ inches).
4. Firkin: 240 mm diameter (9½ inches).

It was possible to compare the regulations, as laid down in the statutes, with the archaeological evidence. The statutes laid down requirements including:

1. Timber type.
2. Dimensions.
3. Quality of cask and components.
4. Inspectors and marking the cask heads.

The structure and dimensions of the heads were examined and it became obvious that there were examples which did not conform to the statutes. For instance, the statutes laid

down that for pork and beef casks: 'each and every barrel . . . shall be made of good seasoned white oak or white oak staves, and heads not less than three quarters of an inch thick . . .'¹⁰ One complete and one partial head from 200-pound (91 kg) pork barrels constructed from pine, were noted in the collection. It could be argued that some advantage of the regulation had been taken. A more blatant example of the statute being disregarded was evidenced in the maximum thickness of one complete head, which was 12 mm (½ inch) considerably under the not less than ¾ inch (19 mm) specified by statute. More significantly, poor-standard workmanship was clearly evident with three heads which had the dowel holes drilled too close to the surface of the timber, resulting in splitting. Further evidence of poor quality craftsmanship was apparent in the chime, or bevelled edge of the head, being cut too thin, with resultant warping and splitting; this could be seen on many cask heads.

Cask markings

Almost all cask heads, both partial and complete, had been marked on the top surface by one or a combination of the following types of marks:

1. Brands: burnt into the head with a branding iron. This was done by a produce inspector at Montreal; the brand-marks were defined by statute (Fig. 6).

Fig. 5: Site plans. (a) Hull of vessel. (b) Trench 1. Key to numbers: (1) Outer planking. (2) Frames. (3) Partial salt beef tierce. (4) Barrel staves. (5 & 6) Tierce staves. (7-12) Complete salt beef tierces. (13) Iron concretion. (14) Partial salt beef tierce. (15) Salt pork barrel lid. (16) Iron concretion. (17) Puncheon (whisky?).

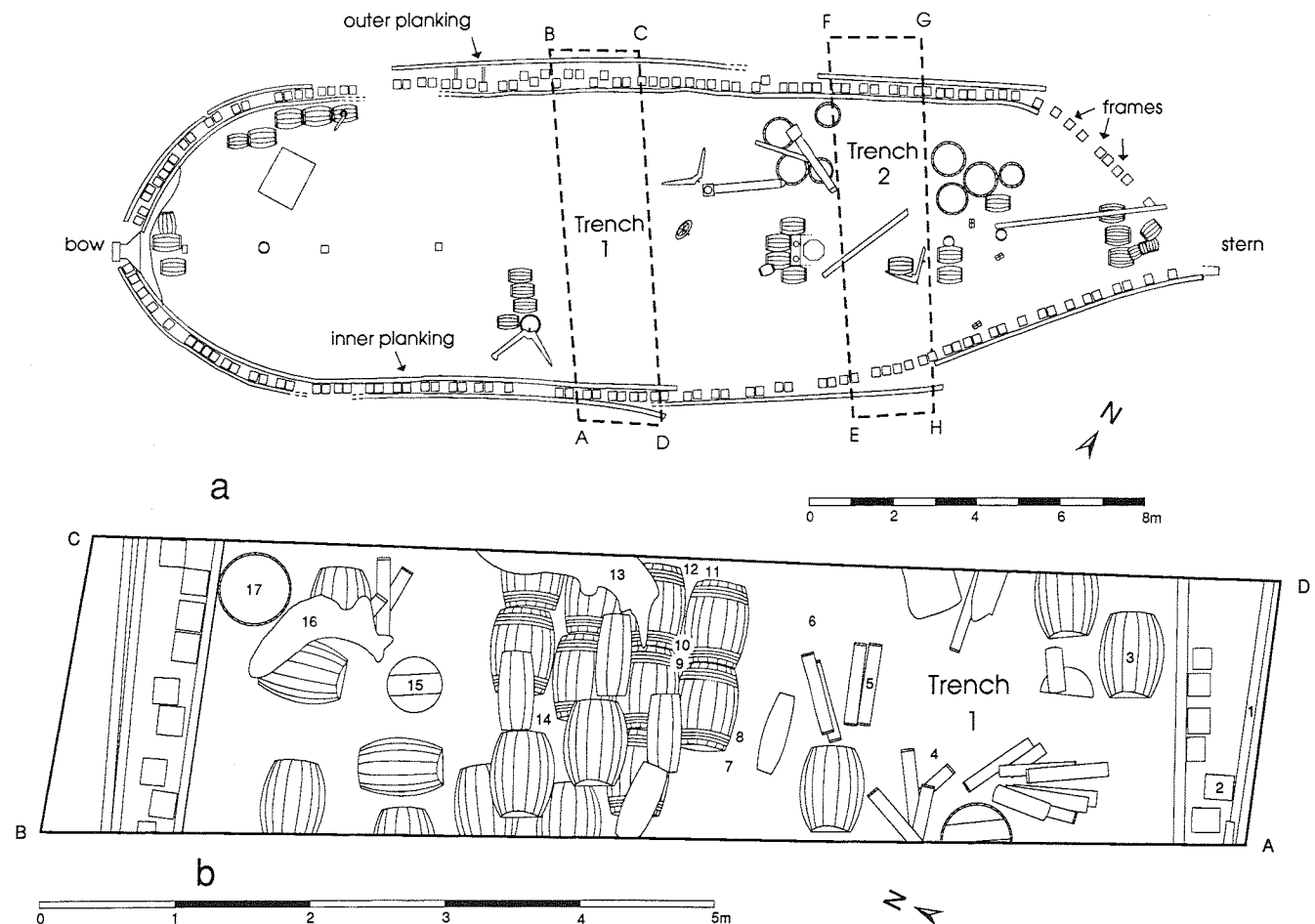

2. Stencils: painted onto the head with a cut-out stencil. This was only noted on flour casks and all examples were marked 'Lachine Mills'. Thus stencils had only been used by a manufacturer (Fig. 6).
3. Letter marks: deeply cut into the head with a sharp instrument (possibly a chisel). These were usually a single letter or a combination of letters (Figs 6-8).
4. Curved-line marks: fine lines cut into the head with a knife, using another head as a curved edge, or made by dividers.
5. Straight-line marks: fine lines cut into the head with a knife, using a straight edge, or cut free-hand (Fig. 8).
6. Circular marks: fine lines cut into the head with dividers. Usually two complete or partial concentric circles.

Of the six types of marks which were seen on the casks, only the brands were defined by the requirements of the statutes. The statutes stated that each cask should be branded with the following information:

1. Weight in pounds.
2. Quality or grade.
3. Contents.
4. Initial and surname of the inspector.
5. Name of the city in which inspected.
6. 'L.C.' for Lower Canada.
7. Year and month of inspection.

Inspectors were required to provide their own branding irons and it is interesting to speculate on the reasons for the apparent error in one of William Watson's branding irons. He was a Montreal flour inspector and the reversed 'N' in 'JUNE' (Fig. 6) is perhaps a case of having had the branding iron made and discovering it to be incorrect, simply deciding to continue using it in order to avoid the added expense of having another made. It was specifically prohibited for

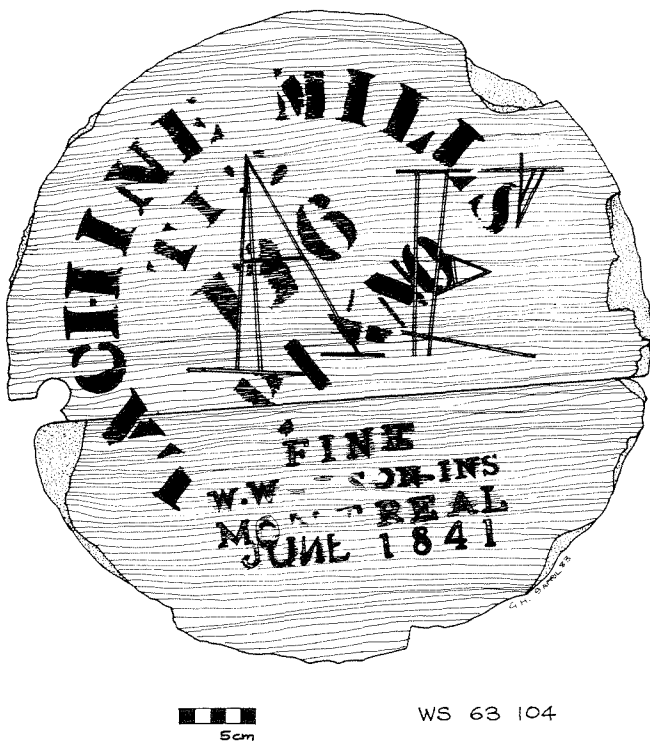

Fig. 6: Cask head. (Drawn by Geoff Hewitt.)

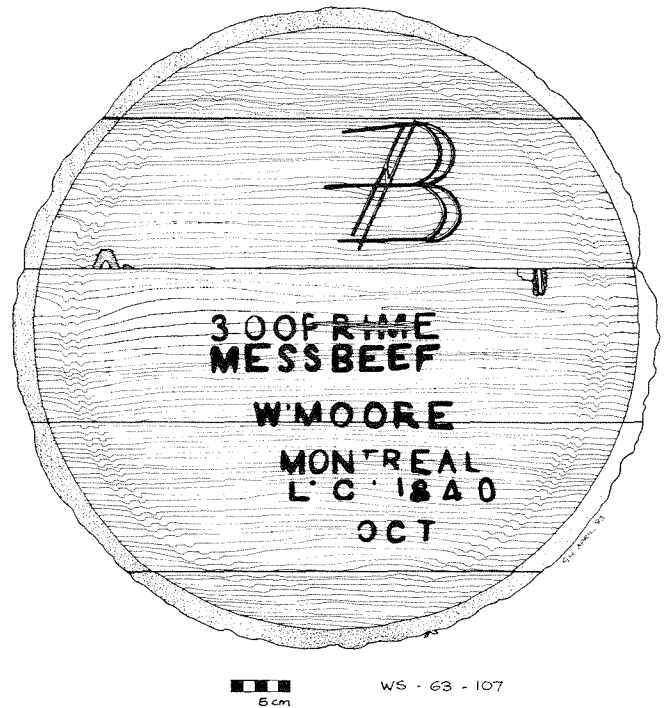

Fig. 7: Cask head. (Drawn by Geoff Hewitt.)

inspectors to have a financial interest in the trade or export of flour. In fact, the inspector was required to take the following oath before a court of law: 'I will not, directly or indirectly, by myself or by any other person or persons whomsoever, trade or deal in flour or meal, or be concerned in any such trade.'¹¹ William Watson was married to one of the daughters of Alexander Ogilvie, the owner of the largest flour mill on the Lachine Canal near Montreal. His brothers-in-law and later his nephews were all involved in the manufacture, sale and export of flour from Montreal. Undoubtedly, the concept of conflict of interest was recognised at the time, as evidenced by the need for the oath; however, the regulation was less than totally effective in practice.

The relevant statute¹² defined four grades of pork in terms of their quality, in the following order:

- Mess Pork: the highest quality.
- Prime Mess Pork: 2nd quality.
- Prime Pork: 3rd quality.
- Cargo Pork: the lowest quality.

The cargo manifest stated that the vessel was carrying 355 barrels of Prime Mess Pork.¹³ However, the eight complete barrel heads which are described in Table 2, illustrate that in fact there were at least three different grades of pork present in the cargo: one barrel of Mess Pork, five of Prime Mess Pork and two of Prime Pork.

Ross¹⁴ provides a description of the marks found on whale-oil barricas (casks) from the wrecksite of the *San Juan*, which he divides into two main categories: exterior and interior marks. No evidence of interior marks was found during the examination of the cask remains from the *William Salthouse*. Consequently, discussion of cask markings will be restricted to the exterior marks. Ross divided the exterior marks found on whale-oil barricas into six categories:

1. Assembly marks.
2. Cooper's inspection, grading and/or makers' marks.
3. Shippers' marks.

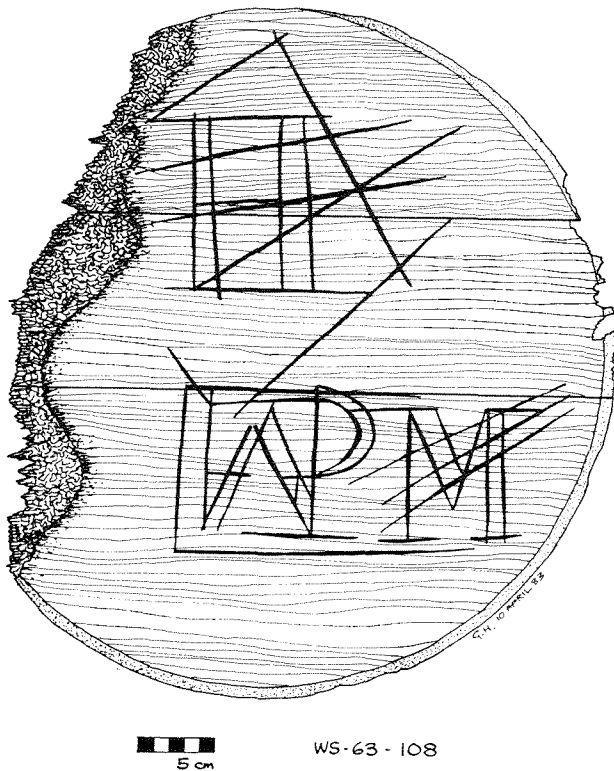

Fig. 8: Cask head. (Drawn by Geoff Hewitt.)

4. Roman numerals.
5. Circular marks.
6. Miscellaneous marks.

Ross noted that all these categories of marks appeared on both heads and staves. However, the only examples of marking on the staves from the *William Salthouse* were of the straight-line variety (Type 5: see beginning of this subsection). Examination of five of the six types of marks found on the *William Salthouse* heads, revealed that there were many similarities with those found on the whale-oil barricas (the latter did not have Type 1 marks).

Stencil marks (Type 2) were only found on the flour casks and were examples of makers' marks: the company which milled and packed the flour had marked the cask with a painted stencil. There were no examples of stencil marks found by Ross but those from the *William Salthouse* correspond to his Category 2 (Coopers'/makers' marks).

Letter marks (Type 3) closely resembled Ross' shippers' marks (Category 3) and it is considered likely that these marks were intended to identify the shipper of the cask.

Curved-line marks (Type 4) consisted of one double X and one single X, noted on complete cask heads, and four

indistinct examples on partial cask heads. Ross found four different types of curved-line marks including the X mark and has suggested that these are coopers' inspection, grading and/or makers' marks (Category 2).

Straight-line marks (Type 5) were the most common marks on the casks, occurring on seventeen partial or complete heads and on two staves. Many of these may have been tally marks (corresponding to Ross' Category 4) which were used when counting, or tallying, the casks, while others may have served to identify shippers.

Finally, circular marks (Type 6) were noted on four heads and were identical to those which Ross described as Category 5, suggesting that they may be coopers' or shippers' marks. However, it is also possible that they are a position-mark for a bung-hole to be cut, as they are of a similar size and in the correct position for a bung.

Staves

The statute¹⁵ required that: 'the wood . . . shall . . . be free from every defect'. While it was difficult to assess some of the defects in the casks, as damage may have occurred after the vessel sank, there were examples of the use of poor quality timber. Thus three staves had substantial knots in the timber. Warping and splitting also occurred with some staves, usually where the staff was cut too thin at the edge. This would probably have resulted in leakage from the cask. Staves were required to be not less than ½ inch (12 mm) thick at each edge at the bilge. Thirty per cent of the staves examined were less than ½ inch, mostly in the range of 10-11 mm, thus falling slightly below the standard required by the statute.

Casks: discussion

Ross¹⁶ has postulated, with regard to sixteenth-century Basque casks, that coopering technology had not reached its pinnacle and that many improvements were to be realized in subsequent centuries. The whale-oil barricas which he examined were completely organic in construction: no metal was used. He makes the point that container strength and durability were improved in later centuries by increasing the stoutness of the staves and heads, by the increased use of metal components, and by the substitution of iron bands for wooden hoops. The results obtained from the test excavation of the *William Salthouse* would suggest that during the nineteenth century, presumably the peak of cooperage technology, dry-coopered casks were still constructed mainly of organic materials. The only evidence of metal found was the use of small iron nails to attach the hoop material to the cask.

There is no question that cooperage technology improved between the sixteenth-century examples described by Ross and those examined from the nineteenth-century wreck of the *William Salthouse*. The division of the trade into three

Table 2: Pork barrel heads.

Weight	200	200	200	200	200	200	200	200
Contents	Prime Pork	Prime Mess Pork	Prime Mess Pork	Prime Mess Pork	Mess Pork	Prime Pork	Prime Mess Pork	Prime Mess Pork
Inspector	Moore	—	W. Moore	W. Moore	W. Moore	W. Moore	W. Moore	W. Moore
Origin	Montreal	—	Montreal	—	Montreal	Montreal	Mont.	Montreal
Date	L.C. 1841 June	—	L.C. 1841 Marc	—	L.C. 1841 Marc	—	L.C. 1841 Marc	L.C. 1841 Marc
Brand	—	M.	—	—	—	double B	—	—

branches, the introduction of the use of iron hoops for liquid-tight casks, and increasingly specialized tools, could produce better quality casks which required a greater level of skill to construct. There was no longer the need to make casks with seven head-pieces, which required head-reinforcing pieces in order to prevent them leaking as was often the case with the barricas. However, the division of cooperage into three branches may have resulted in better quality wet-coopered casks but it can also be said to have resulted in the production of low quality 'throw-away' casks through the dry-cooperage process.

Furthermore, while the technology had advanced, there was still a dramatic variation in the standard of the casks produced. British North America introduced legislation in an attempt to regulate the quality of the components and to maintain a high standard of workmanship. Burns¹⁷ points out that 165 statutes were enacted over the 110-year period between 1758 and 1867, to regulate and control all aspects of the inspection, packaging, shipment and sale of eight groups of consumer commodities. The legislation became more exacting in its requirements during this period. However, there is clear archaeological evidence that in some cases these requirements were not adhered to. The regularity with which the statutes were repealed or amended, suggests that it was recognized by the authorities that the provisions could not be kept. The casks from the *William Salthouse* illustrate that even a small archaeological sample contains examples which did not conform to the statutes in terms of dimensions, timber type and standard of workmanship. They also demonstrate that an inspection service could not be entirely effective in preventing the use of sub-standard components or poor quality workmanship. Certainly the nineteenth-century casks compare poorly with the sixteenth-century barricas, if one considers Ross' comment '... the quality of workmanship is relatively high with little or no apparent tool errors'.¹⁸

Stowage

Bilge and cantline was the most common and preferred method of cask-stowage aboard nineteenth-century sailing vessels. While the interior of a sailing ship is a suitable shape for the stowage of casks by this method, it is not perfectly suited to the task. There will always be awkward spaces which are not suitable and consequently other stowage methods will be used on any vessel. This is demonstrated in the case of the *William Salthouse* by the vertical stowage of the puncheons of whisky and hogsheads of vinegar (Fig. 5). Furthermore, a firkin excavated from next to the main-mast was stowed a-burton, or across the vessel.

To prevent the casks from moving around below decks, a system of quoins (or beds) and wedges was used. As the partial excavation did not reach the lowest tier of casks, only a few examples of this system were found. These included a rough-cut log, flat on one side with a curved section cut out of the upper surface; a large, loose wedge; and several wooden wedges attached directly to the ceiling, or inner, planking of the hull. While the quoins and wedges were used to prevent gross movements of the cask cargo, dunnage was used to prevent casks from rubbing against each other or the vessel's planking. Most contemporary texts on stowage describe dunnage as consisting of tree branches or bamboo jammed between the casks. In the *William Salthouse*, branches, bamboo, rope and surplus hoop material were found to have been utilized as dunnage. The historical documentation perhaps suggests that dunnage was a purpose-designed material, chosen with particular qualities in mind to do a specific task. The archaeological evidence clearly shows that it was an opportunistically selected material: basically whatever was readily available.

THE CARGO

Taken as a whole, the casks can add to our knowledge of the early years of the settlement at Port Phillip. The first question would be why the settlement required such a cargo of salted provisions and flour. There are two possible hypotheses which may answer this question, the first related to the use of salted provisions aboard ships and the second related to the overall demand within the colony for food supplies.

One market for the casks would have been a ship's victualling agent or chandlery. There is no record of a salting works being established at Port Phillip during the first five years of settlement. It is likely that there was no major production of salted provisions for shipboard consumption before the late 1840s. The main reason for this was the low livestock levels in the colony, including a marked shortage of pigs. Consequently, the colony could not supply sufficient quantities of livestock for slaughter, salting down, and sale to visiting vessels. Such vessels would require reprovioning after their long voyage from Britain. However, if vessels required provisions and the colony could not supply this need, one wonders why the ships could not have sailed to another port in Australia where such provisions would have been more readily available. The answer is that studies of maritime history¹⁹ suggest that vessels mainly operated from a single port in Britain to a single port in Australia. They did not voyage from port to port, for very good economic reasons such as port-fees and the time involved. Thus, it would have been an expensive and time-consuming exercise to voyage to Sydney simply to reprovion. The ships represented a captive market: they needed provisions and would be willing to pay for them.

A proposed victualling scale for 1847²⁰ indicated that a seaman consumed one twelfth of a tierce of beef and one tenth of a barrel of pork per month. Thus, a vessel of approximately the same size as the *William Salthouse* with a crew of ten or twelve, would require at least four tierces of salted beef and four barrels of pork to sustain the crew on the four-to-five month return voyage to Britain. When one considers that there were 272 shipping departures from Port Phillip in 1841,²¹ the cask cargo carried by the *William Salthouse* would have been enough to supply approximately one third of these vessels with sufficient salted provisions to complete their voyage back to Britain. For a ship's victualling agent, this would have been an essential and very lucrative cargo.

The second likely market for the cask cargo was the settlement itself. There is evidence that the rapidly increasing population was putting a strain on the settlement's food supply. The population increased from 11,738, in March 1841, to 20,416 in December 1841.²² Such a massive increase in population (nearly 74 per cent) had resulted from increased immigration to the colony. Even before 1841, food supply had sometimes been a problem, a fact that was alluded to by several correspondents. Superintendent Lonsdale wrote to the Colonial Secretary in London in November 1838: 'that there is scarcely any land under cultivation in this district . . . There is no grain remaining unconsumed . . .'²³ In April 1840 the Governor closed the commissariat store, which had previously supplied many colonists. Thus, it is not surprising that there was a need for a cargo of salted provisions and flour.

CONCLUSION

The casks from the wreck of the *William Salthouse* have provided information about cooperage technology, the marking of casks, cask contents, and stowage methods in a nineteenth-century sailing vessel. From a comparison with

the archaeological results of the excavation of the sixteenth-century Basque whaling galleon *San Juan* and available nineteenth-century documentation, it has been possible to demonstrate the use of poor quality components and sub-standard workmanship in the construction of some of the casks from the *William Salthouse*. Despite increasingly sophisticated cooperage technology, the nineteenth-century dry-coopered casks were still almost entirely organic in construction and in some ways compared poorly with the quality of components and workmanship demonstrated in the construction of the whale-oil barricas of three centuries earlier.

The similarities between the cask marking of the sixteenth and nineteenth-century examples and the introduction of a standardised system of cask branding in British North America, have been discussed. Also, the legislation to regulate standards and the introduction of an inspection scheme to ensure that the regulations were enforced, have been shown to have been only partially effective.

The casks which remain on the wrecksite of the *William Salthouse* represent a unique archaeological resource in Australia. The potential to answer more sophisticated research questions about cooperage technology, cask markings, cask contents (including butchering techniques) and stowage is high, particularly when one considers that there are still dozens of casks which remain intact and *in situ* on the wrecksite. The sheer volume of material ensures that there is considerable scope for investigations of this wrecksite by archaeologists in the future.

ACKNOWLEDGEMENTS

I should particularly like to thank the staff of the Victoria Archaeological Survey who were involved in the test excavation of the *William Salthouse* and in the subsequent research and conservation of the cask material. Thanks are also due to the members of the Maritime Archaeology Association of Victoria, who provided valuable assistance, in particular Geoff Hewitt for his excellent drawings of cask heads. In addition, the information supplied by Lester Ross and Robert Burns of Parks Canada is greatly appreciated.

NOTES

1. Hughes 1925: 25.
2. Ross 1985: 3–8.
3. Thomas 1942: 86–90; Stevens 1894: 103.
4. Ross 1980a: 1–14, 1980b: 26–46.
5. Razzolini 1978: 1–9, 1980: 1–4.
6. Burns 1983: 1–19.
7. Staniforth & Vickery 1984: 1–3.
8. *P.P.H.* 10/12/1841.
9. Staniforth & Vickery 1984: 1–35.
10. 2 Vic. Cap. 15, 1839: 160.
11. 2 Vic. Cap. 59, 1839: 18.
12. 2 Vic. Cap. 15, 1839: 164.
13. *P.P.G.* 10/12/1841.
14. Ross 1980b: 156–70.

15. 2 Vic. Cap. 15, 1839: 161.
16. Ross op. cit.
17. Burns 1983: 2.
18. Ross 1980a: 4.
19. Bach 1976: 93–114.
20. Charlwood 1981: 195.
21. Syme 1984: 55–71.
22. Boys 1935: 129.
23. *ibid.*

BIBLIOGRAPHY

Published sources

- BACH, J. 1976. *A maritime history of Australia*, Pan Books, Sydney.
- BOYS, R.D. 1935. *First years at Port Phillip*, Melbourne.
- BURNS, R.J. 1983. Bulk packaging in British North America, 1758–1867, *Parks Canada Research Bulletin*, No. 208.
- CHARLWOOD, D. 1981. *The long farewell*, Allen Lane, Melbourne.
- HUGHES, A.C. 1925. Cooperage antiquity: a wooden barrel 2450 years old, *Barrel and Box* 30(8): 25.
- RAZZOLINI, E.M. 1978. British powder barrels, *Parks Canada Research Bulletin*, No. 90.
- RAZZOLINI, E.M. 1980. Powder barrel markings, *Parks Canada Research Bulletin*, No. 130.
- ROSS, L.A. 1980a. Basque whale-oil casks from a 16th-century ship sunk in Red Bay, Labrador, *Parks Canada Research Bulletin*, No. 123.
- ROSS, L.A. 1980b. *Sixteenth-century Spanish Basque coopering technology*, Parks Canada Manuscript Report Series, No. 408.
- ROSS, L.A. 1985. 16th-century Spanish Basque coopering, *Historical Archaeology* 19(1): 1–31.
- STANIFORTH, M. & VICKERY, L. 1984. *The test excavation of the William Salthouse wreck site*, Australian Institute for Maritime Archaeology Special Publication No. 3.
- STEVENS, R.W. 1894. *On the stowage of ships and their cargoes*, Longmans, Green & Co, London.
- SYME, M. 1984. *Shipping arrivals and departures, Victorian ports, 1798–1845*, Roebuck Books, Canberra.
- THOMAS, R.E. 1942. *Stowage: the properties and stowage of cargoes*, Brown, Son & Ferguson, Glasgow.

Published sources: statutes of the British Dominion of Canada

- 2 Vic. Cap. 15, 1839 Lower Canada. *An ordinance to regulate the curing, packing and inspection of beef and pork, intended for exportation.*
- 2 Vic. Cap. 59, 1839 Lower Canada. *An ordinance to suspend for a limited time, certain sections of the ordinance for the better packing and inspection of flour and meal.*

Newspapers

- Port Phillip Gazette (P.P.G.)*
Port Phillip Herald (P.P.H.)